

KS B1503 20k Flange Dimensions

KS B1503 20K FLANGE DIMENSIONS

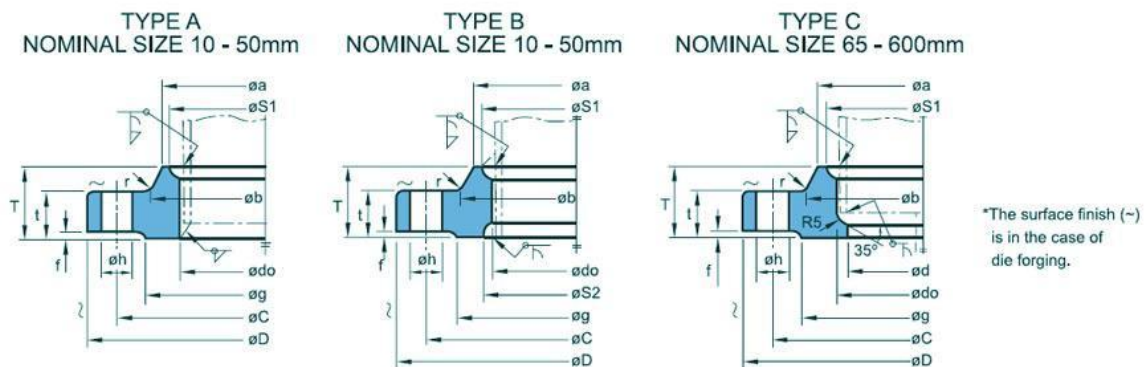

Nominal Diameter of Flanges	Outside Diameter of Flanges D	flange Sectional Dimensions								
		Diameter of Bolt Circle C	Diameter Of raised Face g	Inside Diameter Of Flanges do	O.D. of Steel pipe	t	T	Hub Diameter		Radius r
								a	b	
10	90	65	46	17.8	17.3	14	20	30	32	4
15	95	70	51	22.2	21.7	14	20	34	36	4
20	100	75	56	27.7	27.2	16	22	40	42	4
25	125	90	67	34.5	34	16	24	48	50	4
32	135	100	76	43.2	42.7	18	26	56	60	5
40	140	105	81	49.1	48.6	18	26	62	66	5
50	155	120	96	61.1	60.5	18	26	76	80	5
65	175	140	116	77.7	76.3	20	30	100	104	5

80	200	160	132	90	89.1	22	34	113	117	6
-90	210	170	145	102.6	101.6	24	36	126	130	6
100	225	185	160	115.4	114.3	24	36	138	142	6
125	270	225	195	141.2	139.8	26	40	166	172	6
150	305	260	230	166.6	165.2	28	42	196	202	6
200	350	305	275	218	216.3	30	46	244	252	6
250	430	380	345	269.5	267.4	34	52	304	312	6
300	480	430	395	321	318.5	36	56	354	364	8
350	540	480	440	358.1	355.6	40	62	398	408	8
400	605	540	495	409	406.4	46	70	446	456	10
450	675	605	560	460	457.2	48	78	504	514	10
500	730	660	615	511	508	50	84	558	568	10
-550	795	720	670	562	558.8	52	90	612	622	10
600	845	770	720	613	609.6	54	96	666	676	10
*650	945	850	790	664	660.4	60				
*700	995	900	840	715	711.2	64				
*750	1080	970	900	766	762	68				
*800	1140	1030	960	817	812.8	72				
*850	1200	1090	1020	868	863.6	74				
*900	1250	1140	1070	919	914.4	76				

KS B1503 20K FLANGE INDUSTRIES AND APPLICATIONS

WIDELY USED IN THE INDUSTRIES

- Pumps, Valves, and vessels in manufacturing and food processing.
- Pipe connections in industrial waterworks.
- Heat exchangers and heating systems of all sizes.
- Mining support.
- Nuclear power systems.
- Plumbing and mechanical systems.
- Assemblies in the oil, gas, and petrochemical industries.
- Fire protection systems.