

## API 6A Type 6B 3000PSI Blind / Welding Neck Flange

DIMENSION OF 3000PSI (20.7MPA) TYPE 6B BLIND AND API 6A WELDING NECK FLANGE

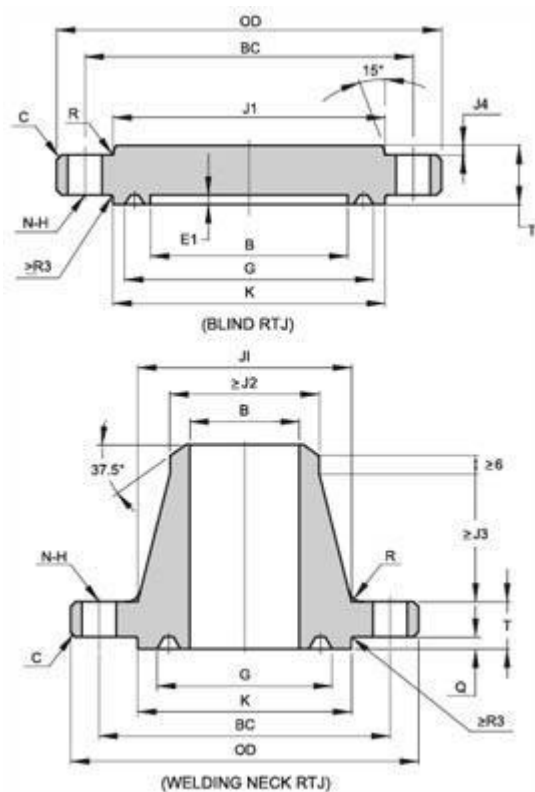

Size	B	OD	C	K	P	E	T	Q	X	BC	N	H	LN	HL	JL
2 1/16"	53.2	215	3	124	95.25	7.9	46.1	38.1	104.8	165.1	8	26	109.6	60.3	50
2 9/16"	65.9	245	3	137	107.95	7.9	49.3	41.3	123.8	190.5	8	29	112.7	73	59.7

3 1/8"	81.8	240	3	156	123.83	7.9	46.1	38.1	127	190.5	8	26	109.5	88.9	74.4
4 1/16"	108.7	290	3	181	149.23	7.9	52.4	44.4	158.8	235	8	32	122.2	114.3	98
5 1/8"	131	350	3	216	180.98	7.9	58.8	50.8	190.5	279.4	8	35	134.9	141.3	122.9
7 1/16"	181.8	380	6	241	211.15	7.9	63.5	55.6	235	317.5	12	32	147.6	168.3	147.1
9"	229.4	470	6	308	269.88	7.9	71.5	63.5	298.5	393.7	12	39	169.9	219.1	189.7
11"	280.2	545	6	362	323.85	7.9	77.8	69.9	368.3	469.9	16	39	192.1	273	237.2
13 5/8"	346.9	610	6	419	381	7.9	87.4	79.4	419.1	533.4	20	39	-	-	-
16 3/4"	426.2	705	6	524	469.9	11.2	100.1	88.9	508	616	20	45	-	-	-
20 3/4"	527.8	855	6	648	584.2	12.7	120.7	108	622.3	749.3	20	54	-	-	-

1. RING NUMBER R or RX, 2. C should be the max value 3. Tolerance and Ring Gasket according to API 6A-20TH

## API 6A TYPE 6B 3000PSI BLIND / WELDING NECK FLANGE INDUSTRIES AND APPLICATIONS

WIDELY USED IN THE INDUSTRIES

- Pumps, Valves, and vessels in manufacturing and food processing.
- Pipe connections in industrial waterworks.
- Heat exchangers and heating systems of all sizes.
- Mining support.
- Nuclear power systems.
- Plumbing and mechanical systems.
- Assemblies in the oil, gas, and petrochemical industries.
- Fire protection systems.