

DIN 2634 PN25 Welding Neck Flange

DIN 2634 PN25 WELDING NECK FLANGE DIMENSIONS, TECHNICAL DRAWINGS, AND APPROX. FLANGE WEIGHT

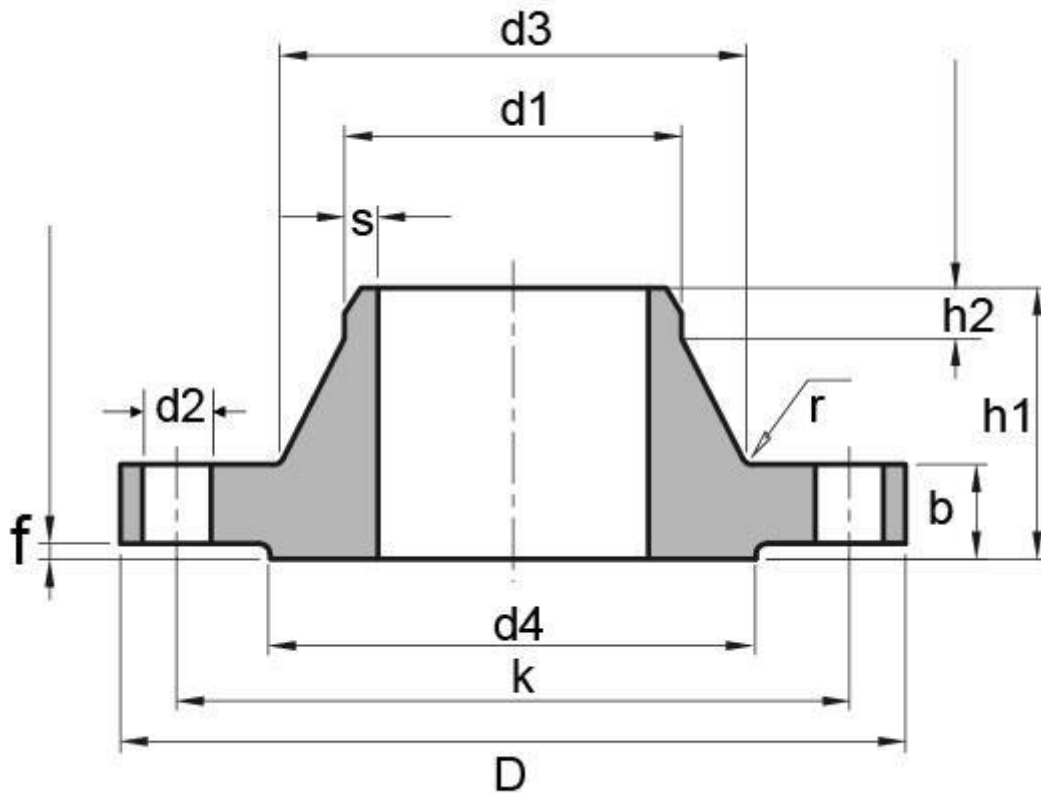

DIN 2634 PN25 WELDING NECK FLANGE DIMENSIONS

Pipe Parameter	d1		Flange Dimension				Neck Size				Hub Size		Screw		Appr Flang Weig KG/P
	ISO	DIN	D	b	k	h1	d3	s	r	h2	d4	f	No. of Holes	d2	
10	–	14	90	16	60	35	25	1.8	4	6	40	2	4	14	0.67
	17.2	–	90	16	60	35	28	1.8	4	6	40	2	4	14	0.66
15	–	20	95	16	65	38	30	2	4	6	45	2	4	14	0.75
	21.3	–	95	16	65	38	32	2	4	6	45	2	4	14	0.75
20	–	25	105	18	75	40	38	2.3	4	6	58	2	4	14	1.07
	26.9	–	105	18	75	40	40	2.3	4	6	58	2	4	14	1.07
25	–	30	115	18	85	40	42	2.6	4	6	68	2	4	14	1.29
	33.7	–	115	18	85	40	46	2.6	4	6	68	2	4	14	1.28
32	–	38	140	18	100	42	52	2.6	6	6	78	2	4	18	1.88
	42.4	–	140	18	100	42	56	2.6	6	6	78	2	4	18	1.86
40	–	44.5	150	18	110	45	60	2.6	6	7	88	3	4	18	2.1
	48.3	–	150	18	110	45	64	2.6	6	7	88	3	4	18	2.08
50	–	57	165	20	125	48	72	2.9	6	8	102	3	4	18	2.81
	60.3	–	165	20	125	48	75	2.9	6	8	102	3	4	18	2.78
65	76.1	–	185	22	145	52	90	2.9	6	10	122	3	8	18	3.61
80	88.9	–	200	24	160	58	105	3.2	8	12	138	3	8	18	4.62
100	–	106	235	24	190	65	128	3.6	8	12	162	3	8	22	6.42
	114.3	–	235	24	190	65	134	3.6	8	12	162	3	8	22	6.27
125	–	133	270	26	220	68	155	4	8	12	188	3	8	26	8.83
	139.7	–	270	26	220	68	162	4	8	12	188	3	8	26	8.61
150	–	159	300	28	250	75	182	4.5	10	12	218	3	8	26	11.67
	166.3	–	300	28	250	75	192	4.5	10	12	218	3	8	26	11.29
175	193.7	–	330	28	280	75	218	5.6	10	15	248	3	12	26	13.11
200	219.1	–	360	30	310	80	244	6.3	10	16	278	3	12	26	16.61
250	–	267	425	32	370	88	292	7.1	12	18	335	3	12	30	23.99
	273	–	425	32	370	88	298	7.1	12	18	335	3	12	30	23.48
300	323.9	–	485	34	430	92	352	8	12	18	395	4	16	30	30.74
350	355.6	–	555	38	490	100	398	8	12	20	450	4	16	33	47.2
	–	368	555	38	490	100	398	8	12	20	450	4	16	33	44.22
400	406.4	–	620	40	550	110	452	8.8	12	20	505	4	16	36	61.69

	–	419	620	40	550	110	452	8.8	12	20	505	4	16	36	57.88
500	508	–	730	44	660	125	558	10	12	20	615	4	20	36	89.57
600	610	–	845	46	770	125	660	11	12	20	720	5	20	39	114.9
700	711	–	960	46	875	125	760	12.5	12	20	820	5	24	42	139.5
800	813	–	1085	50	990	135	865	14.2	12	22	930	5	24	48	188.7
900	914	–	1185	54	1090	145	968	16	12	24	1030	5	28	48	231.4
1000	1016	–	1320	58	1210	155	1070	17.5	16	24	1140	5	28	56	303.5

DIN 2634 PN25 WELDING NECK FLANGE INDUSTRIES AND APPLICATIONS WIDELY USED IN THE INDUSTRIES

- Pumps, Valves, and vessels in manufacturing and food processing.
- Pipe connections in industrial waterworks.
- Heat exchangers and heating systems of all sizes.
- Mining support.
- Nuclear power systems.
- Plumbing and mechanical systems.
- Assemblies in the oil, gas, and petrochemical industries.
- Fire protection systems.