

## DIN 2627 PN400 Welding Neck Flange

DIN 2627 PN400 WELDING NECK FLANGE DIMENSIONS, TECHNICAL DRAWINGS, AND APPROX. FLANGE WEIGHT

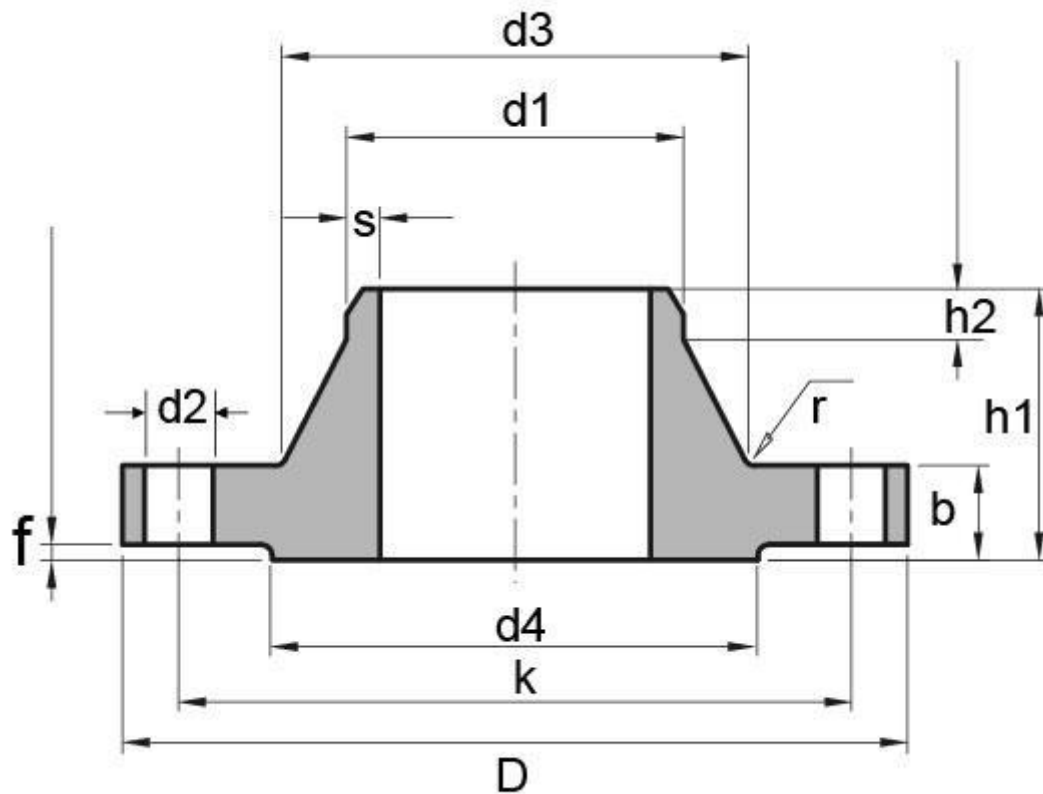

DIN 2627 PN400 WELDING NECK FLANGE DIMENSIONS

Pipe Parameter	d1		Flange Dimension				Neck Size				Hub Size		Screw		Approx Flange Weight
	ISO	DIN	D	b	k	h1	d3	s	r	h2	d4	f	No. of Holes	d2	KG/PCS
10	–	14	125	24	85	58	44	2.6	4	6	40	2	4	18	2.1
	17.2	–	125	24	85	58	44	2.6	4	6	40	2	4	18	2.09
15	–	20	130	26	90	60	48	3.2	4	6	45	2	4	18	2.49
	21.3	–	130	26	90	60	48	3.2	4	6	45	2	4	18	2.49
25	–	30	160	34	115	78	68	5	4	8	68	2	4	22	5.14
	33.7	–	160	34	115	78	68	5	4	8	68	2	4	22	5.11
40	–	44.5	195	38	145	88	92	6.3	6	10	88	3	4	26	8.53
	45.3	–	195	38	145	88	92	6.3	6	10	88	3	4	26	8.47
50	63.5	–	210	42	160	100	106	8	6	10	102	3	8	26	10.52
65	88.9	–	255	51	200	120	138	11	6	12	122	3	8	30	19.26
80	101.6	–	275	55	220	130	156	12.5	8	14	138	3	8	30	24.81
100	–	133	335	65	265	145	186	16	8	16	162	3	8	36	42.18
125	–	159	380	75	310	175	230	20	8	20	188	3	12	36	64.55
	168.3	–	380	75	310	175	230	20	8	20	188	3	12	36	63.3
150	193.7	–	425	84	350	195	265	25	10	25	218	3	12	36	91.04
175	219.1	–	485	95	400	215	308	28	10	28	260	3	12	42	135.46
200	244.5	–	525	103	440	235	345	30	10	30	285	3	16	42	170.94
250	323.9	–	640	125	540	300	428	40	12	40	345	3	16	52	311.99

## DIN 2627 PN400 WELDING NECK FLANGE INDUSTRIES AND APPLICATIONS

WIDELY USED IN THE INDUSTRIES

- Pumps, Valves, and vessels in manufacturing and food processing.
- Pipe connections in industrial waterworks.
- Heat exchangers and heating systems of all sizes.
- Mining support.
- Nuclear power systems.
- Plumbing and mechanical systems.
- Assemblies in the oil, gas, and petrochemical industries.
- Fire protection systems.